



Masthead Burgees - Why they are important and how to fit one without difficulty.

We like to think that we are a bit special at “The Thames”. When we come into an anchorage or marina in Northern Europe, the burgee at the masthead is the first indication of who we are, and a quick glance round will show us who else is there, and even, perhaps, who might have a noggin on offer. We will probably find just two other clubs with pennants at the masthead, the Squadron and the Royal Cruising Club. It looks splendid when our burgees are all fluttering mast high at a meet. It is not difficult to achieve, even for the racing man. So here are some tips, ranging from the professional yard supplied installation to that of the DIY man like myself.

THE POP-UP for the racing man. It is up only when you need it. Understandably, racers do not want any extra windage at the masthead. On that quintessential racing yacht “Bear of Britain”, they did it by having a hoist fixed to a shackle attached to the head of the sail and using a really long burgee staff. It was easily stowed when racing and in a blow no one noticed anyway. In harbour they made the main halyard into a loop and attached the shackle for the burgee hoist to that.

THE BISHOPS CROOK for the smart cruising man. This is available from manufacturers such as Selden and Formula Spars for about £500 before installation. Your local stainless fabricator will charge much less. It comprises a steel or carbon rod, attached to the head of the mast, bent at the top way above the electronic cluster, with a pulley for the hoist attached to the tip. If it is tall enough, there is no need for a flag staff.

THE PERPENDICULAR. This is similar to the crook but without the bend and one can use similar materials. I used the top of an old dinghy mast which is tapered with a pulley in the top. It has lasted ten years so far. The Vice Commodore has a smart stainless steel affair. The burgee staff should be long - I used an old optimist spar. The poles of fishing rods are also light and strong. The hoist is attached to the burgee staff just below the burgee; taking the fall through a hole in the bottom of the staff rather than using a second knot makes it hang more vertically. Hoisting can be a challenge, depending on the wind direction. I found that the tip of the burgee got caught in the aerial on windless days and solved this by fixing a ping pong ball to the end of the aerial with a blob of araldite. An even longer mast or burgee staff would be another solution.

However we do it, let us proudly display our burgees at the masthead:

“There are many different ways of singing tribal lays, and each and every one of them is right”.

Peter Tracey

Some Members' Solutions

Tony Bird on Carinya: The Bishop's Crook

Tony's comments:

My burgee mast was made by our local stainless steel fabricator at Chichester Marina, whose principal business is pulpits, pushpits outboard cranes etc.

The unit was made from a stainless steel rod with a four-hole plate welded to the lower end for riveting to the top of mast. At the peak of the burgee mast there is a small ring through which we lead the burgee halyard, or one could use a small block for the same purpose. The whole unit is tall enough to clear the instruments and bent away from the main mast to starboard, to keep the burgee clear.

The burgee itself is fixed to a length of aluminium pole for stability and can be raised and lowered on the halyard as required. The key to success was to bend it away from the mast. Total cost around £80, although I did fix it myself. It's a long way up!

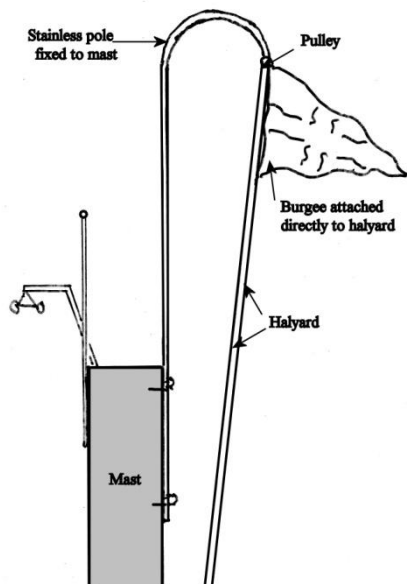
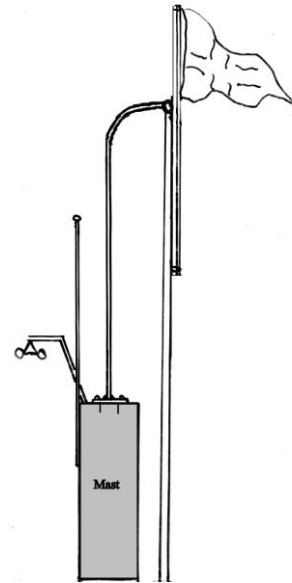

Ian Pearce on Matterhorn: The Bishop's Crook

Ian's comments:

On *Matterhorn* we were confronted with the usual problems of paraphernalia on the mast head and the need to raise the burgee above everything. Mo Pimm at Pro Mo Marine (who looks after the *Matterhorn* for us) organised the fabrication of the curved staff/pole just over 2m in length, at a cost of £38.00 (plus VAT) which is screwed into the mast.

Due to the stress imposed on it we have had to reinforce the fixings with stronger, larger screws although we think it looks smart, it does periodically foul the wind vane and has moved it so that our GPS heading appeared to be about 30 degrees different to the compass and one's first impression is the compass has developed a big problem.

John Stork on Ciconia: The Perpendicular

John's comments:

I have drawn something out that shows the extra strut I use - this has the advantage of lifting the hoisting point of the burgee staff above the mast and so making it all more stable.

However this arrangement is a little dangerous for the wind instrument and I always have my heart in my mouth as the flag goes up. If possible I try and do it when the wind is blowing over the port side as the strut is to starboard (unfortunately the prevailing wind in our berth is the other way!).

There are two alternative refinements - either put the wind instrument transducers as far forward as possible, or move the strut as far aft. The first is probably best.

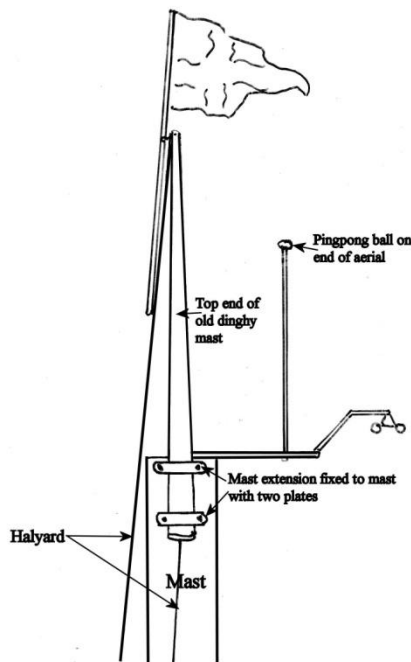
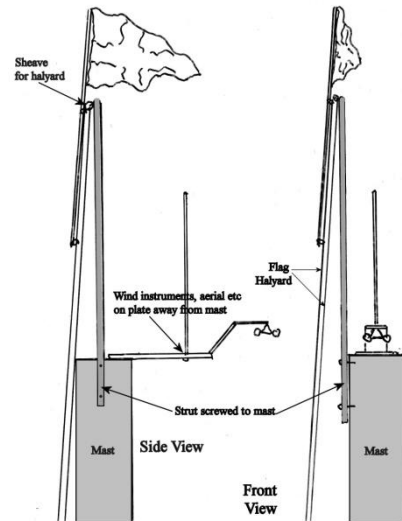

Peter Tracey on Shambhala: The Perpendicular

Peter's comments:

Around the back of many sailing clubs there is a stack of broken dinghy masts. Many are nicely tapered with a pulley in the top. It is not difficult to chop off the top 2 metres and attach it to the top of the mast. I did this up aloft using two plates as illustrated. After ten years there is no sign of wear or failure.

The burgee staff should be long - I used an old optimist spar. The hoist is attached to the burgee staff just below the burgee; taking the fall through a hole in the bottom of the staff rather than using a second knot makes it hang more vertically. Hoisting can be a challenge, depending on the wind direction.

The Ping Pong Ball Fix

It is bad news if the end of the burgee gets caught in the top of the aerial. The simple solution is to glue a ping pong ball to the top of the aerial. Providing one uses enough filled araldite, it is amazing how the ball survives.

Comparisons of different designs

The advantage of the Bishops Crook is that it takes the halyard away from the mast so that it is less likely to frap at night. In addition there may be fewer problems with fouling instrumentation, particularly wind vanes. With this design it is also possible to use the burgee without a pole. However there is a lot of strain up there and the construction must be strong enough. It could be rather dramatic if it collapsed on to instruments when offshore.